

www.tapflo.com

Quality grade
CT centrifugal pumps
catalogue 2009



tapflo®



Tapflo - your reliable pumpchoice

With experience from industrial fluid handling and pump manufacture since 1970, we know what you as a customer require from an industrial pump. Ever since we started our manufacture of air operated diaphragm pumps, we have always had our winning concept in mind: to create pumps for reliable duty and with a minimal number of components enabling easy maintenance. We are always keenly aware of new requirements and ideas from our customers. The products are therefore always in continuous progress with improved detail solutions, new materials and further accessories.

Tapflo quality

The Tapflo pump is usually an essential part in the process with hazardous fluids. We always strive to supply the safest and most environmental friendly solution for these fluids. As a part of our safety thinking, we are in the frontline following important standards, guidelines and directives. Many of our products comply with the EC ATEX directive for equipment in explosion hazardous environments. All our pumps are of course CE marked and followed by our comprehensive instruction manuals. Tapflo is an ISO 9001:2001 certified company.

The history of Tapflo

Tapflo was founded in Kungälv (north of Gothenburg), Sweden 1985 and has since then been working with design and manufacture of air operated diaphragm pumps. The product range has grown from a few plastic models, to complete PE & PTFE, metal and sanitary series and lately also with complete ranges of centrifugal pumps. Within the Tapflo group today 200 employees are working in design, production and sales.

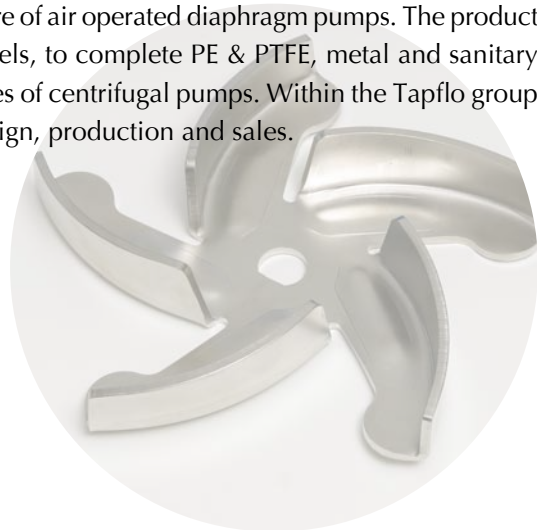

▼ The compact centrifugal pump

The CT range

With 2900 rpm motor:

CTAA-03	7 m ³ /h, 10 m
CTAA-05	12 m ³ /h, 10 m
CTBB-07	17 m ³ /h, 11 m
CTCC-15	19 m ³ /h, 22 m
CTCC-22	34 m ³ /h, 22 m
CTCE-22	20 m ³ /h, 31 m
CTDD-40	50 m ³ /h, 22 m
CTDF-40	28 m ³ /h, 35 m
CTDF-60	42 m ³ /h, 35 m
CTDG-60	30 m ³ /h, 47 m
CTEF-55	42 m ³ /h, 35 m
CTEG-55	30 m ³ /h, 47 m

With 1450 rpm motor:

CTAA-024	7 m ³ /h, 2.7 m
CTBB-054	9 m ³ /h, 2.8 m
CTCC-114	18 m ³ /h, 5.5 m
CTCE-114	22 m ³ /h, 7.7 m
CTDD-224	25 m ³ /h, 5.5 m
CTDF-224	34 m ³ /h, 8.7 m
CTDG-224	42 m ³ /h, 12.0 m



CT is an open impeller centrifugal pump, manufactured from stainless steel AISI 316L. With excellent electro polished surfaces, high finish and mechanical strength, the CT range meet the demands from a variety of today's industries. After all, CT is still available at a very appealing price level.



Explosion proof models available according to the ATEX directive, group II, cat 2.

For a variety of industries

The CT range has a very wide range of applications – from transfer of water, to pumping of chemicals. Below are a few common industrial fields and applications for the CT range.



Food-, beverage- and pharmaceutical industries

A variety of auxiliary applications, like transfer of water, edible oil, alcohols, detergents and CIP cleaning liquids

Chemical industry

Transfer of a variety of mild chemicals and solvents

Mechanic industries

Handling of water and coolants etc

▼ Features & benefits ▼

Quick and easy maintenance

CT is normally maintenance free. When necessary, the CT pump is very simple to maintain thanks to the small number of components – only 19 different parts. Most of these components will last “a lifetime”. The good effect is short down time and low maintenance costs.

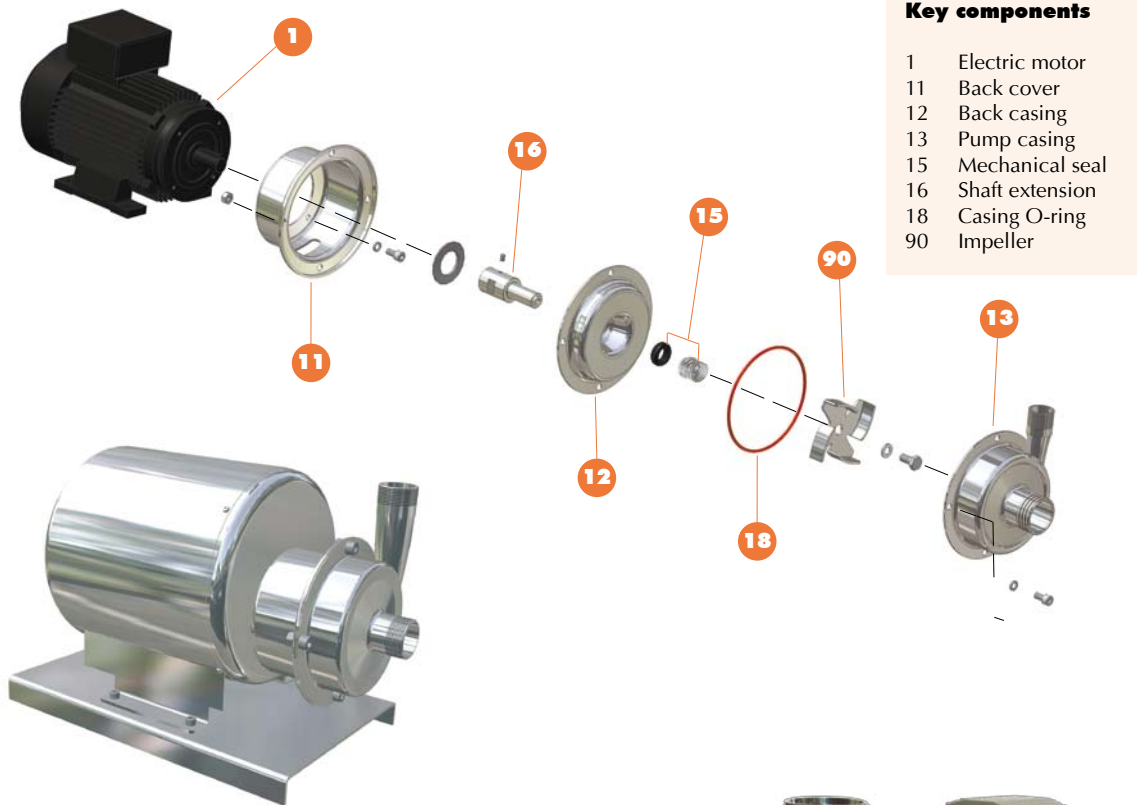

Key components	
1	Electric motor
11	Back cover
12	Back casing
13	Pump casing
15	Mechanical seal
16	Shaft extension
18	Casing O-ring
90	Impeller

Options and special executions

- Hygienic motor shroud and baseplate in stainless steel (above)
- Long coupled pump on baseplate allowing temperatures up to 180°C (right)
- Heating jacket to maintain a certain temperature
- Flushed seal (water or oil)
- Drain plug

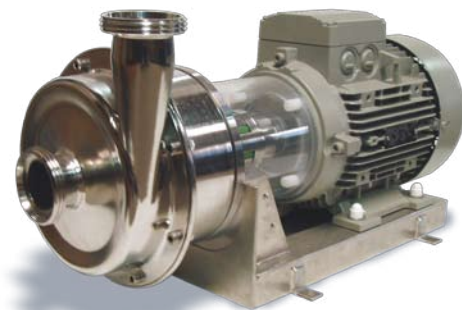

Interchange ability mechanical seal

Many different seal faces are available, to suit different liquid types. The internal mounting provides superior cooling from the liquid.



Solids with open impeller

The open type impeller is insensitive for solids. Maximum size of solids is 6 mm, or even bigger if soft. The one-piece high finish design provides silent pumping.



Flexible choice of drive

The smart design of this shaft extension allows fitting any IEC standard type motor to the pump. I.e. you are able to choose required voltage, protection class, explosion protection etc.

Performance curves

The performance curves are based on water at 20°C.



With 2900 rpm motor

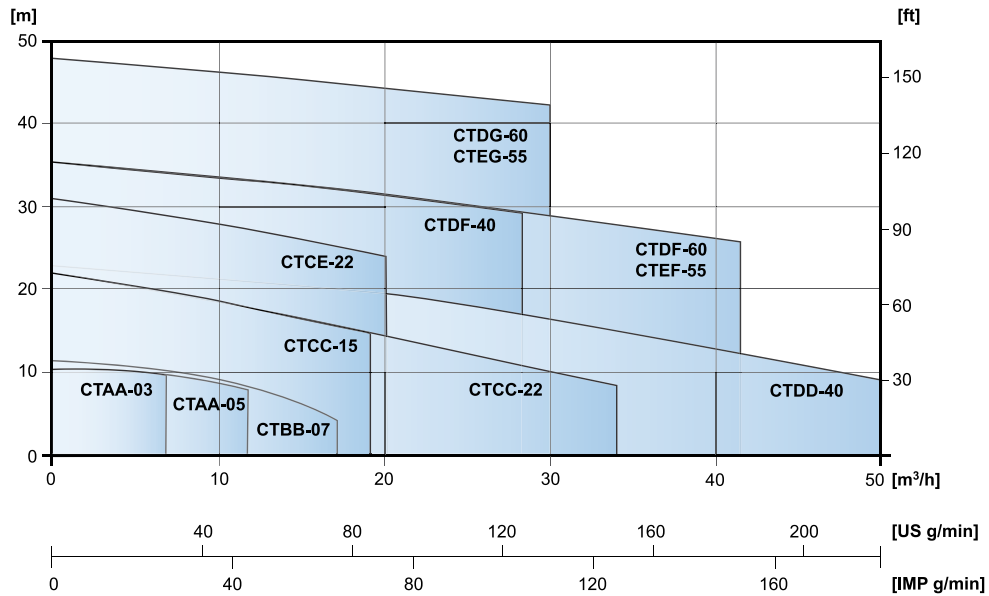

With 1450 rpm motor

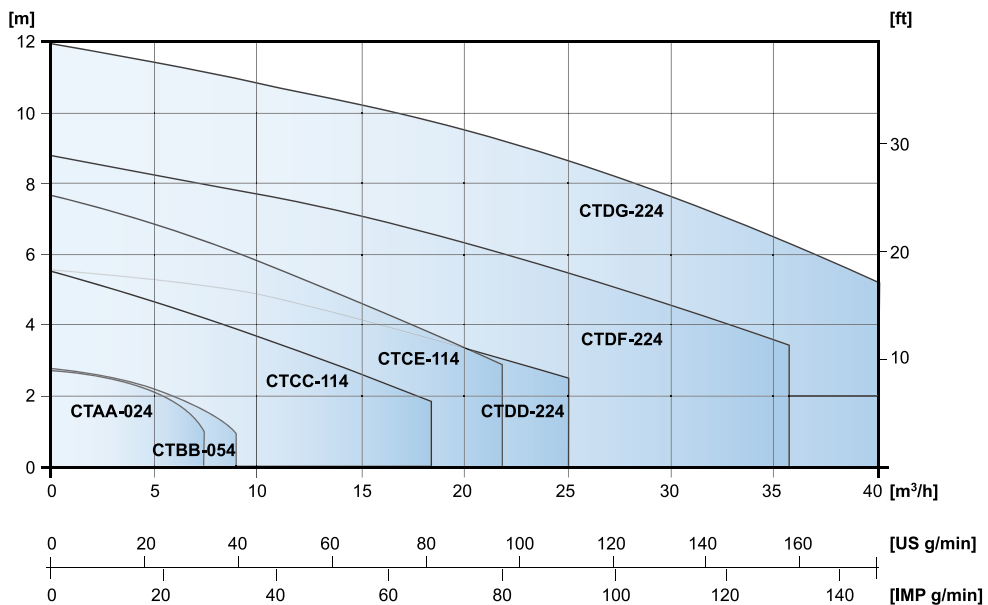

Contact us for detailed curves. Changes reserved without notice

Dimensions

Dimensions in mm, where other is not indicated

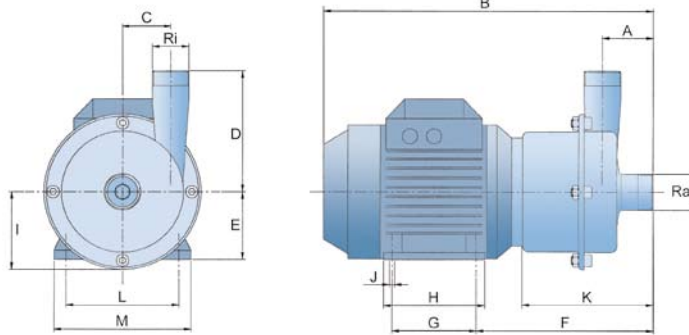

Optional connections

Model	Optional connections			
	SMS		DIN 11851	
	Ra	Ri	Ra	Ri
CTAA	1"	1"	25	25
CTBB	1 1/2"	1"	40	32
CTCC	1 1/2"	1 1/2"	40	40
CTCE	1 1/2"	1 1/2"	40	40
CTDD	2 1/2"	2"	65	50
CTDF	2 1/2"	2"	65	50
CTDG	2 1/2"	2"	65	50
CTEF	2 1/2"	2"	65	50
CTEG	2 1/2"	2"	65	50

General dimensions

Model	Motor power (kW)	IEC motor size	Ra	Ri	A	B**	C	D	E	F	G	H**	I	øJ	K	L	M**
CTAA-03	0.37	71	1"	3/4"	60	359	36	100	71	197	90	112	73	7	147	112	135
CTAA-05	0.55	71	1"	3/4"	60	359	36	100	71	197	90	112	73	7	147	112	135
CTBB-07	0.75	80	1 1/2"	1"	63	393	50	110	80	208	100	125	86	9	153	125	153
CTCC-15	1.5	90	1 1/2"	1 1/2"	64	444	66	160	90	228	125	150	103	10	169	140	170
CTCC-22	2.2	90	1 1/2"	1 1/2"	64	444	66	160	90	228	125	150	103	10	169	140	170
CTCE-22	2.2	90	1 1/2"	1 1/2"	64	444	66	160	90	228	125	150	103	10	169	140	170
CTDD-40	4	112	2 1/2"	2"	70	493	92	192	100	255	140	172	128	12	195	160	197
CTDF-40	4	112	2 1/2"	2"	70	493	92	192	100	255	140	172	128	12	195	160	197
CTDF-60	6.0*	112	2 1/2"	2"	70	521	92	192	112	262	140	168	128	12	195	190	222
CTDG-60	6.0*	112	2 1/2"	2"	70	521	92	192	112	262	140	168	128	12	195	190	222
CTEF-55	5.5	132	2 1/2"	2"	70	586	92	192	132	304	140	208	128	12	195	216	242
CTEG-55	5.5	132	2 1/2"	2"	70	586	92	192	132	304	140	208	128	12	195	216	242
CTAA-024	0.25	71	1"	3/4"	60	359	36	100	71	197	90	112	73	7	147	112	135
CTBB-054	0.55	80	1 1/2"	1"	63	393	50	110	80	208	100	125	86	9	153	125	153
CTCC-114	1.1	90	1 1/2"	1 1/2"	64	444	66	160	90	228	125	150	103	10	169	140	170
CTCE-114	1.1	90	1 1/2"	1 1/2"	64	444	66	160	90	228	125	150	103	10	169	140	170
CTDD-224	2.2	112	2 1/2"	2"	70	493	92	192	100	255	140	172	128	12	195	160	197
CTDF-224	2.2	112	2 1/2"	2"	70	493	92	192	100	255	140	172	128	12	195	160	197
CTDG-224	2.2	112	2 1/2"	2"	70	521	92	192	112	262	140	168	128	12	195	190	222

* = Special motor with increased power. Not available in EX-proof version

** = This dimension may vary depending on motor brand

Technical data and limits

Limits

Temperature:	max 90°C, max 180°C for long coupled version
Viscosity:	max ~200 cSt
Particles:	max diameter 6 mm (bigger if soft)

Changes reserved without notice

www.tapflo.com

Tapflo is represented in more than 50 countries worldwide. Visit our website for updated information.



Tapflo offices

Belarus

Tapflo Belarus
Tel: +375 17 3121370
Fax: +375 17 3121370

Bulgaria

Tapflo EOOD
Tel: +359 (0) 888 765 288
Fax: +359 (2) 974 18 54

Czech & Slovakia

Tapflo s.r.o.
Tel: +420 734 49381
Fax: +420 548 138661

China

Tapflo (Wuxi)
Tel: +86 510 8241 7602
Fax: +86 510 8241 6807

Denmark

Tapflo Danmark
Tel: +45 36 454600
Fax: +45 36 453500

France

Tapflo France
Tel: +33 1 34 78 82 40
Fax: +33 1 34 78 82 41

India

Tapflo Pumps (India)
Tel: +91 44 42103695
Fax: +91 44 26203479

Ireland

Tapflo Ireland Ltd
Tel: +353 1 2011911
Fax: +353 1 2011912

Italy

Tapflo Italia
Tel: +39 0362307698
Fax: +39 0362307697

Kazakhstan

Tapflo Kazakstan
Tel: +7 702 626 7997
Fax: +7 702 626 7997

Latvia

Tapflo Latvia
Tel: +371 7472205
Fax: +371 29288837

Poland

Tapflo Sp. z o.o.
Tel: +48 58 5301181
Fax: +48 58 5324767

Romania

S.C. Tapflo Rom. S.r.l.
Tel: +40 21 3451255
Fax: +40 21 3451166

Russia

OOO Tapflo
Tel: +7 095 2411017
Fax: +7 095 2411017

Spain

Tapflo Iberica
Tel: +34 91 8093182
Fax: +34 91 8093157

South Africa

Tapflo (Pty) Ltd
Tel: +27 41 5831412
Fax: +27 41 5831704

Turkey

Tapflo Makina Ltd
Tel: +90 216 467 33 11
Fax: +90 216 467 33 42

Ukraine

TOB Tapflo
Tel: +380 44 222 68 44
Fax: +380 44 222 68 45

United Kingdom

Tapflo (UK) Ltd
Tel: +44 2380 252325
Fax: +44 2380 269016

tapflo®

Swedish office

Tapflo AB

Filaregatan 4, S-442 34 Kungälv, Sweden
Tel: +46 303 63390, Fax: +46 303 19916
E-mail: sales@tapflo.com, internet: www.tapflo.com